

ADDRESS KJELLER HALDEN N-2007 Kjeller, Norway N-1751 Halden, Norway TELEPHONE +47 2 712560 - 713560 +47 31 83100 TELEX 74 573 energ n 76 335 energ n TELEFAX +47 2 715553		AVAILABILITY Private Confidential
REPORT TYPE	REPORT NO. 484 IFE/KR/F-86/035	DATE 1986-03-05
	REPORT TITLE REPORT ON STABLE ISOTOPES ON A GAS SAMPLE FROM WELL 6407/6-2, FEBRUARY 1986	DATE OF LAST REV. REV. NO.
	CLIENT Statoil	NUMBER OF PAGES 3
	CLIENT REF. T-6269, avrop nr. 70.	NUMBER OF ISSUES 15
SUMMARY The gas components C ₁ -C ₄ and CO ₂ are quantified and the δ ¹³ C value is measured on C ₁ and C ₂ . The isotopic composition of hydrogen of C ₁ has also been measured.		DISTRIBUTION Statoil (10) Andresen, B. Brevik, E.M. Råheim, A.
<div style="border: 1px solid black; padding: 10px; width: fit-content; margin: auto;"> <p>BA 86-4744-1</p> <p>- 9 APR. 1986</p> <p>REGISTRERT</p> <p>OLJEDIREKTORATET</p> </div>		
KEYWORDS		
NAME	DATE	SIGNATURE
PREPARED BY Bjørg Andresen Einar M. Brevik Arne Råheim	1986-03-05 1986-03-05 1986-03-05	<i>Bjørg Andresen</i> <i>Einar M. Brevik</i> <i>Arne Råheim</i>
REVIEWED BY		
APPROVED BY Karen Garder	1986-03-05	<i>Karen Garder</i>

1. ANALYTICAL PROCEDURE

The gas sample from well 6407/6-2 has been quantified and separated into the different gas components by a Carlo Erba 4200 instrument. This gas chromatograph is equipped with a special injection loop in order to concentrate the samples, in the case of low concentration of the gas components.

The methane and ethane were oxidized in separate CuO ovens in order to prevent cross contamination. The combustion products CO₂ and H₂O were frozen into collection vessels and separated.

The water was reduced with zinc metal in a sealed tube to prepare hydrogen for isotopic analysis. The isotopic measurements were performed on a Finnigan Mat 251 mass spectrometer. Our $\delta^{13}\text{C}$ value on NBS-22 is $-29.77 \pm .06$ o/oo.

2. RESULTS

The results of the isotopic determinations are given in Table 1. Our uncertainty on the $\delta^{13}\text{C}$ value is estimated to be $\pm .3$ o/oo, and includes all the different analysis steps. The uncertainty on the δD value is likewise estimated to be $\pm .5$ o/oo.

The composition of the gas sample is given in Table 2. The results have been normalized.

Table 1 Isotopic composition of a gas sample from well 6407/6-2, February 1986

Sample	IFE no.	$\delta^{13}\text{C}_{\text{C}_1}$	δD	$\delta^{13}\text{C}_{\text{C}_2}$
6407/6-2	4597	-71.5	-197	-51.5

Table 2 Composition of a gas sample from well 6407/6-2,
February 1986

Sample	IFE no.	C ₁ %	C ₂ %	C ₃ %	i-C ₄ %	n-C ₄ %	CO ₂ %	ΣC ₁ -C ₄	$\frac{\Sigma C_2-C_4}{\Sigma C_1-C_4}$	$\frac{i-C_4}{n-C_4}$
6407/6-2	4597	99.95	0.04	2.5×10^{-3}	1.3×10^{-4}	1.3×10^{-4}	0.01	99.99	5.3×10^{-4}	1.0

3. INTERPRETATION

The gas is a dry gas. It is only possible to determine the $\delta^{13}\text{C}$ values of methane and ethane in the present case. The cross plots between $\delta^{13}\text{C}$ and δD methane (after Schoell*, 1983). Fig. 1, indicate a gas of biogenic origin.

* Schoell, M. (1983): Genetic Characterization of Natural Gases, AAPG, December 1983.

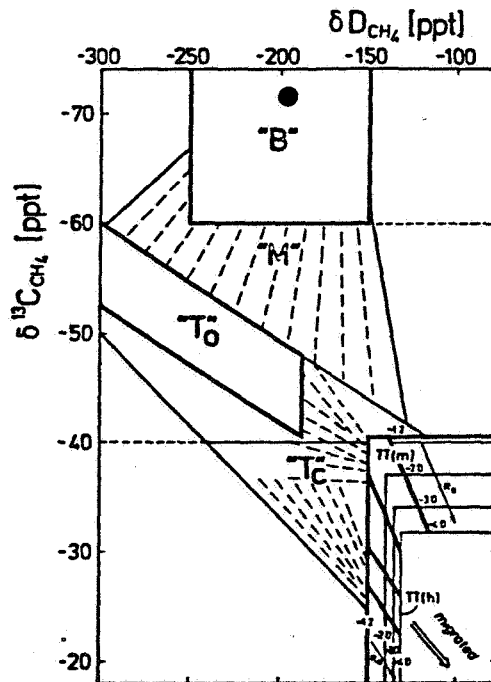

Figure 1 Carbon and hydrogen isotope variations in methane.

The principle for the genetic characterization of natural gases is that the primary gases (B-biogenic gas, T-associated gas, TT-non-associated gas) are defined by fields of compositional variations. These primary gases may become mixed and form various mixtures "M" of intermediate composition. "TT(m)" and "TT(h)" are non-associated gases from marine source rocks and coal gases from N.W. Germany, respectively, compositional shifts due to migration are indicated by arrows Md (deep migration) and Ms (shallow migration), respectively. "T₀" are gases associated with petroleum in an initial phase of formation. "T_c" are gases associated with condensates. (Schoell 1983).

1. ANALYTICAL PROCEDURE

The gas sample from well 6407/6-2 has been quantified and separated into the different gas components by a Carlo-Erba 4200 instrument. The hydrocarbon gas components were oxidized in separate CuO ovens in order to prevent cross contamination. The combustion products CO₂ and H₂O were frozen into collection vessels and separated.

The water was reduced with zinc metal in a sealed tube to prepare hydrogen for isotopic analysis. The isotopic measurements were performed on a Finnigan Mat 251 mass spectrometer. Our $\delta^{13}\text{C}$ value on NBS-22 is $-29.77 \pm .06$ o/oo.

2. RESULTS

The results of the isotopic determinations are given in Table 1. Our uncertainty on the $\delta^{13}\text{C}$ value is estimated to be $\pm .3$ o/oo, and includes all the different analysis steps. The uncertainty on the δD value is likewise estimated to be $\pm .5$ o/oo.

Table 1

Sample	C ₁		CO ₂	
	$\delta^{13}\text{C}$	δD	$\delta^{13}\text{C}$	$\delta^{18}\text{O}$
6407/6-2	-70.4	-192	-21.9	-4.6

The composition of the gas sample is given in Table 2. The results have not been normalized to 100%. The rest is air and H₂O vapor.

Table 2

C ₁	64%
C ₂	0.02%
C ₃	0.001%
CO ₂	0.9%

3. INTERPRETATION

The gas is a dry gas. The amount of ethane and propane are too small to determine the δ^{13} values in the present case. The cross plots between δ^{13} C and δ D methane (after Schoell* 1983), Fig. 1, indicate a gas of biogenic origin.

The carbon isotope composition of the CO₂ associated with the formation of biogenic CH₄ (fermentation zone) is normally expected to be enriched in ¹³C (isotopically heavy). This is, however, not the case in the present situation (δ^{13} C = -21.9). The CO₂ gas may therefore have formed in the sulphate reduction zone or perhaps in this case more likely in the decarboxylation zone.

4. CONCLUSION

The gas is dry and the stable isotopic results are characteristic of a biogenic origin.

The CO₂ gas in the sample is not likely to be originally associated with the formation of biogenic CH₄. The CO₂ gas may originally either be formed in the sulphate reduction zone or in the decarboxylation zone.

* Schoell, M. (1983): Genetic characterization of Natural Gases, AAPG, December 1983.

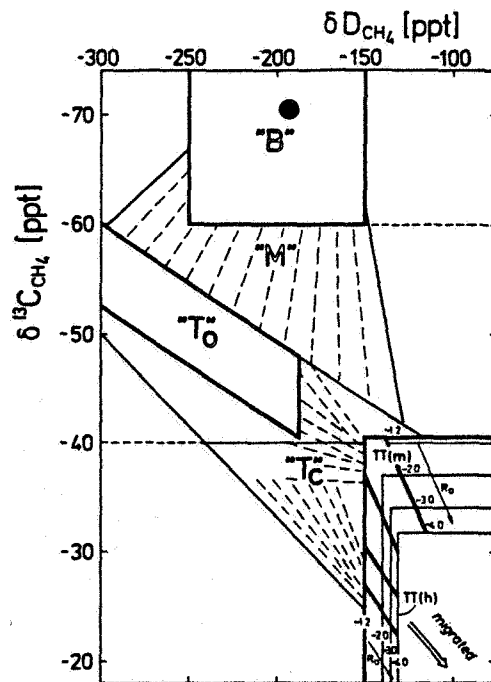

Figure 1

Carbon and hydrogen
isotope variations
in methanes.

The principle for the genetic characterization of natural gases is that the primary gases (B-biogenic gas, T-associated gas, TT-non-associated gas) are defined by fields of compositional variations. These primary gases may become mixed and form various mixtures "M" of intermediate composition. "TT(m)" and "TT(h)" are non-associated gases from marine source rocks and coal gases from N.W. Germany, respectively, compositional shifts due to migration are indicated by arrows Md (deep migration) and Ms (shallow migration), respectively. "T₀" are gases associated with petroleum in an initial phase of formation. "T_c" are gases associated with condensates. (Schoell 1983).